

# YAR 205-015-2F

## Dimensions

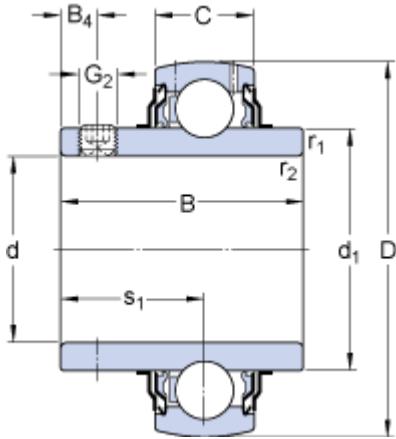

d		23.812	mm
D		52	mm
B		34.1	mm
C		15	mm
d <sub>1</sub>	≈	33.74	mm
B <sub>4</sub>		5	mm
r <sub>1,2</sub>	min.	0.6	mm
s <sub>1</sub>		19.8	mm

## Calculation data

Basic dynamic load rating	C	14	kN
Basic static load rating	C <sub>0</sub>	7.8	kN
Fatigue load limit	P <sub>u</sub>	0.335	kN
Limiting speed with shaft tolerance h6		7000	r/min
Calculation factor	f <sub>0</sub>	14	

## Mass

Mass bearing	0.21	kg
--------------	------	----

## Mounting information

Thread grub screw	G <sub>2</sub>	1/4-28 UNF
Hexagonal key size for grub screw	N	3.175 mm
Recommended tightening torque for grub screw		4 N·m

## Appropriate products

Rubber seating ring	RIS 205
---------------------	---------